

# FRP-Confined Masonry: from Experimental Tests to Design Guidelines

M.A. Aiello, F. Micelli & L. Valente

*Department of Innovation Engineering, University of Salento - Via per Monteroni, 73100 Lecce, ITALY*

**ABSTRACT:** Historical masonry construction are prone to brittle failures under seismic or static overloads. Thus retrofit and strengthening of masonry structures, in order to furnish structural ductility and additional strength, is of primary importance for the maintenance of the European Architectural Cultural Heritage. Confinement with Fibre Reinforced Polymer (FRP) materials demonstrated to be an effective solution in a large number of cases. In this research program extensive experimental tests were conducted to calibrate design guidelines for FRP-confined masonry columns, which were introduced in the CNR DT-200 Italian document. Columns built with lime or with calcareous blocks, commonly found in Italy in historical buildings, were tested under compression static loads. Rectangular masonry columns were tested taking into account the influence of several variables: different strengthening schemes, curvature radius of the corners, number of composite layers, cross-section aspect ratio and height of the specimens. Materials characterization was carried out to study the properties of plain masonry. For all cases the experimental tests evidenced a significant increase in load carrying capacity and ductility after FRP-strengthening, which identified the columns as ductile elements despite to the brittle nature of the unconfined masonry. Differences in mechanical behavior due to the geometry of the columns, to the nature of different materials, to different strengthening schemes and to the amount of reinforcement are presented and discussed in the paper. The calibration of design equations recently developed by Italian CNR was conducted by using experimental results.

## 1 INTRODUCTION

The structural performance of columns can be easily improved by adequate strengthening solutions which can use innovative materials. In this paper a study on the mechanical behavior of masonry columns confined with Fiber Reinforced Polymer (FRP) sheets and subjected to axial compression is illustrated. The problem of FRP-confinement was extensively studied in relation to concrete columns. A large number of analytical and experimental results allowed to carry out design recommendations that are commonly accepted by the scientific community. On the other hand a few data are available for masonry columns subjected to high compressive loads and strengthened by FRP materials. Recent studies furnished results on the stress-strain relationship of RC-jacketed masonry columns (Kog et al. 2001). Today, the urgent need to develop effective methods of masonry confinement as a means of preventing catastrophic failure during earthquakes, of guaranteeing an adequate safety level under increased load due for instance to changed usage, or even of restoring damaged constructions, has pushed the writers to lead the experimental and analytical studies presented herein.

Krevaikas and Triantafyllou (2006) investigated the mechanical properties of masonry rectangular columns strengthened with FRP and developed an analytical model in which the hardening factors were calibrated by using experimental results on 42 small-scale specimens. Other experimental investigations on this topic are reported in Micelli et al. (2003) and Aiello et al. (2007). However the number of results is still not sufficient to define an adequate stress-strain

relationship of the FRP strengthened columns. In order to allow a successfully application of this technology in practice, reliable tools for design must be developed, and their validation through experimental results is necessary. This research was focused on strengthening of masonry columns with square cross section confined with FRP external sheets and FRP internal bars. Hollow core columns were also tested in order to see the effectiveness of the proposed technique in these well-known cases. Different corner radius, amount of FRP and type of masonry blocks were mainly the investigated variables. Design equations recently proposed in CNR (2004) were verified by using the experimental data obtained in this research.

## 2 SPECIMENS AND EXPERIMENTAL TESTS

Materials characterization was carried out to investigate the mechanical properties of the materials involved in the experimental program. Material characterization included tests of FRP specimens, masonry triplets, masonry blocks and mortar specimens. FRP specimens were prepared and tested according to ASTM D3039, testing was performed in displacement-control mode using a 150-kN universal testing machine, with a cross-head displacement rate of 2 mm/min. In particular five unidirectional GFRP (Glass FRP) specimens were tested. Mechanical properties were experimentally evaluated for each specimen and results averaged. An electrical extensometer was used to measure the strain of FRP under tensile force. A tensile strength of 1605 MPa resulted from tensile tests, with a standard deviation of 147 MPa. The experimental elastic modulus was 74143 MPa, with a standard deviation of 4683 MPa. Tensile properties of the GFRP ( $\Phi=8$  mm) rebars were also measured on five specimens, according to ACI 440K guidelines: average strength was 803 MPa with a standard deviation of 39 MPa, the experimental elastic modulus was 40170 MPa, with a standard deviation of 4309 MPa. Five 30x120x20 mm specimens of stones were tested according to UNI 9724-4, under flexural loads with three-point loading scheme with a span of 100 mm. A flexural strength of 6 MPa resulted with a standard deviation of 0.5 MPa. In order to measure the flexural strength of the mortar used to build the columns, five 40x40x160 mm mortar specimens were tested according to UNI EN 196-1. A value of 4.56 MPa was measured for the flexural strength, with standard deviation of 0.96 MPa. Failed specimens were subjected to compression test according to UNI EN 196-1, and a compressive strength of 7.80 MPa was measured, with standard deviation of 0.85 MPa. The mortar used in this research is classified as M3, according to the Italian national code for masonry buildings and this contained cement and lime as binder, at water/cement/lime-sand ratio equal 1:1:5 by weight. The mechanical characterization of masonry units was done by compression tests on natural masonry triplets built with three 100x150x30 mm blocks and 10 mm mortar joints. A compression strength of 13.61 MPa resulted with a standard deviation of 1.00 MPa for limestone masonry. For triplets made with clay bricks a compression strength of 23.29 MPa resulted with a standard deviation of 1.00 MPa. Thirty-one columns were prepared using different constituent materials and following two different construction schemes. Each specimen was 50 cm high, bricks were placed in thirteen rows with twelve bed joints in between as shown in Figure 1.

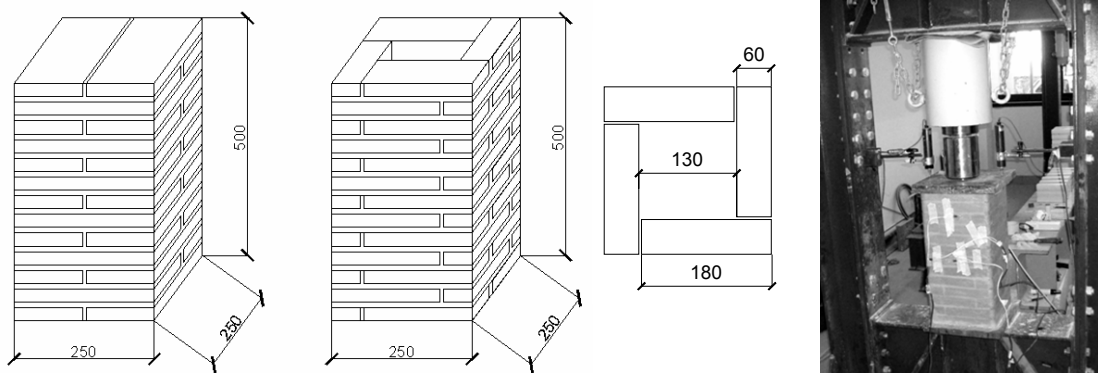

Figure 1 Geometry and test set-up (mm)

The thickness of the mortar bed was 10 mm, the corners of all specimens were rounded using a grinding machine at a radius of 10 mm or at a radius of 20 mm to see the influence of this parameter. Within each series, specimens were wrapped with one or two layers of unidirectional GFRP sheets, that were bonded using an epoxy adhesive. Details about the columns in each series are given in Table 1. Specimens reinforced with internal bars were drilled and the obtained holes cleaned, then GFRP bars with  $\Phi=8$  mm were introduced in the direction perpendicular to the axis of the column, and bonded using an epoxy paste. Hole diameter was of 12 mm. All specimens were tested under axial compression load by means of a 150-ton hydraulic jack reacting against a closed-loop reaction steel frame. In all tests two LVDTs were used to monitor the displacement of the upper face of the column. LVDTs were also placed to monitor possible displacement of the lower steel beam of the frame, in order to take into account only the displacement of the specimen. Load was recorded by means of a 150-ton load cell, and six electric strain gages were applied on the CFRP sheet in the direction of the fibers at different locations: 200, 300 and 400 mm high from the base of the columns. Load, strains and displacements were all recorded by a data acquisition system. All tests were conducted under the same moisture and temperature conditions in order to minimize the effects due to different hygro-thermal conditions.

Table 1. Experimental Program

TEST		DIMENSIONS (mm)			MATERIAL	CONSTRUCTION SCHEME	FRP strengthening scheme		CORNER RADIUS
N°	Label	A	B	H	blocks	Core	Number of GFRP external sheets	Number of GFRP internal bars per each course	r (mm)
1	SFC-1	250	250	500	Limestone	Full	0 - Unconfined	0 - Unconfined	-
2	SFC-2	250	250	500	Limestone	Full	0 - Unconfined	0 - Unconfined	-
3	SFC-3	250	250	500	Limestone	Full	0 - Unconfined	0 - Unconfined	-
4	SFB-1	250	250	500	Limestone	Full	0	2*	-
5	SFB-2	250	250	500	Limestone	Full	0	2*	-
6	SFB-3	250	250	500	Limestone	Full	0	2**	-
7	SFB2-1	250	250	500	Limestone	Full	0	2**	-
8	SFB2-2	250	250	500	Limestone	Full	0	2	-
9	SF1-R1-a	250	250	500	Limestone	Full	1 - Continuous	0	10
10	SF1-R1-b	250	250	500	Limestone	Full	1 - Continuous	0	10
11	SF1-R2-a	250	250	500	Limestone	Full	1 - Continuous	0	20
12	SF1-R2-b	250	250	500	Limestone	Full	1 - Continuous	0	20
13	SF2-R2-a	250	250	500	Limestone	Full	2 - Continuous	0	20
14	SF2-R2-b	250	250	500	Limestone	Full	2 - Continuous	0	20
15	SFBF-1	250	250	500	Limestone	Full	1 - Continuous	2*	10
16	SFBF-2	250	250	500	Limestone	Full	1 - Continuous	2*	10
17	SFB2F-1	250	250	500	Limestone	Full	1 - Continuous	2**	10
18	SFB2F-2	250	250	500	Limestone	Full	1 - Continuous	2**	10
19	SAC-1	250	250	500	Limestone	Hollow	0 - Unconfined	0 - Unconfined	-
20	SAC-2	250	250	500	Limestone	Hollow	0 - Unconfined	0 - Unconfined	-
21	SAF-1-1	250	250	500	Limestone	Hollow	1 - Continuous	0	20
22	SAF-1-2	250	250	500	Limestone	Hollow	1 - Continuous	0	20
23	SAF-2-1	250	250	500	Limestone	Hollow	2 - Continuous	0	20
24	SAF-2-2	250	250	500	Limestone	Hollow	2 - Continuous	0	20
25	SAD-1-1	250	250	500	Limestone	Hollow	1 - Strip	0	20
26	SAD-2-1	250	250	500	Limestone	Hollow	2 - Strip	0	20
27	SAB-1-2	250	250	500	Limestone	Hollow	0	2**	-
28	SAB-2-2	250	250	500	Limestone	Hollow	0	2**	-
29	SAFB-1	250	250	500	Limestone	Hollow	1 - Continuous	2**	20
30	SAFB-2	250	250	500	Limestone	Hollow	1 - Continuous	2**	20
31	LC-1	250	250	500	Clay	Full	0 - Unconfined	0 - Unconfined	-
32	LC-2	250	250	500	Clay	Full	0 - Unconfined	0 - Unconfined	-
33	LF1-R1	250	250	500	Clay	Full	1 - Continuous	0	10

### 3 RESULTS AND DISCUSSION

Control specimens SFC1-2-3 exhibited a brittle failure mode with a maximum average load of 433 kN, which means a compressive strength of 6.93 MPa. Vertical cracks formed at low load level, then they propagated along the principal axis of the column in directions that were

almost parallel to the loading direction. Specimens SF1-R1, externally wrapped with one layer of GFRP and characterized by a corners radius of 10 mm, had a average maximum load of 641 kN with a corresponding compressive strength of 10.33 MPa. The scatter between the tested specimens in terms of ultimate capacity appears related to the low value of the corner radius adopted, since a premature tensile failure of the reinforcement was observed in one of the two tests, typically due to the stresses concentrations at corners. Specimens with increased corner radius, SF1-R2 showed a maximum load of 750 kN which means a compressive strength of the columns equal to 12 MPa, corresponding to a load increase of 73% with respect to unconfined masonry, and of 25% with respect to specimens with a reduced corner radius. As a result the externally wrapping with one GFRP layer globally furnished a relevant strength improvement, even if the influence of a proper corners rounding seems fundamental to avoid a premature failure and thus a drastic decay of the confinement effectiveness.

Limestone specimens SF2-R2 strengthened with two layers of GFRP and corner radius of 20 mm did not show a proportional increase of the ultimate capacity with respect to SF1-R2 specimens, having a maximum average load of 717 kN corresponding to a compressive strength of 13.87 MPa. Therefore doubling the amount of reinforcement the strength increase resulted almost 16% higher.

Referring to columns strengthened only with internal bars, different results were obtained varying the bars spacing. In fact, specimens with bars spaced 160 mm (specimens SFB-1, SFB-2 and SFB-3) did not show an encouraging structural behavior in terms of strength, since the average maximum load was 435 kN corresponding to a compressive strength of 6.96 MPa, very close to that of unconfined columns. As the bars spacing was halved (specimens SFB2-1 and SFB2-2) an average increase of the maximum compressive strength equal to 61% was registered, with respect to the unreinforced specimens and an increase of the axial stiffness was also recorded. The confinement by the combination of internal bars and external wrapping was also tested varying once again the bars spacing. A significant increase in both ductility and strength with respect to unconfined masonry was in all cases obtained, since the maximum load reached a value of 782 kN corresponding to a compressive strength of 12.52 MPa, and 813 kN with a compressive strength of 13.1 MPa, for 160mm and 80 mm bars spacing, respectively. Representative load displacement curves for columns made with limestone blocks are shown in Figure 3.

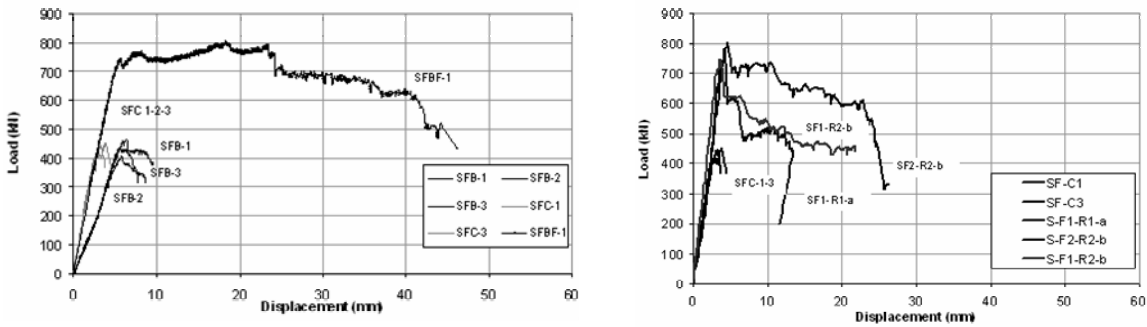

Figure 3 Load-displacement curves for columns built with limestone blocks

Columns that were built using clay bricks showed higher mechanical properties due to the different constituent material. LC-1 and LC-2 (unconfined) specimens collapsed at a maximum load of 857 kN corresponding to a compressive strength of 13.71 MPa. Column LF1-R1 failed due to the tensile rupture of FRP sheets in correspondence of the corner regions, that occurred at an applied load equal to 1228 kN (compressive strength 19.65 MPa). This shows that an increased capacity of 40% in terms of maximum load may be reached also when clay brick masonry is confined. Columns made with limestone, that were built with the hollow core showed a different mechanical behavior if compared to the specimens previously described. That result was expected, since the presence of the hollow core reduces the resistant cross section to the only external walls. Specimens SAC (unconfined) showed a brittle failure mode with an average peak load of 321 kN, which means a compressive strength of 7.03 MPa, corresponding to a value that is 35% less if compared to the correspondent monolithic column. The values of

strength in “SA-” specimens were computed considering only the external walls and not the hollow core. Confinement with one layer of GFRP resulted very effective also in this case since the maximum load was 457 kN (strength 10.02 MPa), that is 40% higher if compared to unstrengthened hollow core specimens. Specimens confined with two layers of GFRP failed by fibers rupture at a maximum load of 486 kN, corresponding to a compressive strength of 10.66 MPa. Once again a low advantage in terms of strength (almost 6%) was obtained when the amount of GFRP is doubled, further reduced with respect to the case of monolithic cross section. Specimens labeled with SAD were confined with one or two GFRP layers using a sheet that had a width of 300 mm, meaning that the two extreme regions of the column, having a high of 100 mm, were not confined. This scheme was used because it is frequent in historical buildings that the presence of decorative parts avoid to strengthen the column for its entire length. Specimens with one layer of GFRP had a maximum load of 381 kN (strength 8.36 MPa) while specimens confined with two layers of GFRP showed a maximum load of 438 kN with a compressive strength of 9.61 MPa. These results confirm how the presence of the GFRP produced a structural advantage also in this case.

Specimens SAB that were built with limestone and hollow core, and strengthened only with internal GFRP bars, had a maximum load was 436 kN corresponding to an increase of 35% with respect to unstrengthened masonry, while the increase in ultimate displacement was about 6%. In specimens SAFB the ultimate load was 664 kN (strength 14.55 MPa), and ultimate axial displacement was 1250% higher than that of unconfined masonry. Figure 4 shows the most representative curves related to hollow-core columns built with limestone blocks and clay columns.

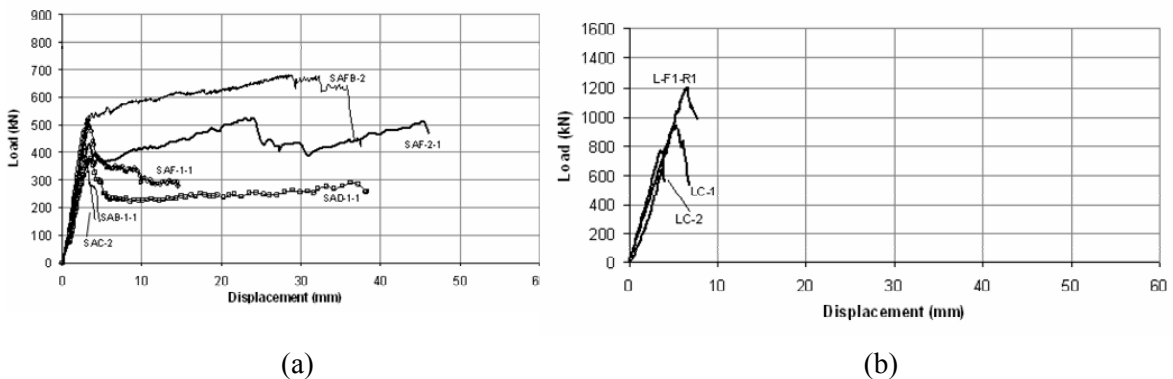

Figure 4. Load-displacement curves for columns built with clay bricks (a) and hollow core (b)

According to the test results it is evidenced here that the quantitative effectiveness of FRP-confinement was dependent from the materials used as blocks in the masonry units: the average strength increase related to the respective control models was about 43% for clay columns, and about 73% for limestone columns. The behavior of hollow-core columns was clearly different with respect to full-core columns: SAF-1 specimens showed an increase of 42.5% in bearing capacity, while full-core specimens with the same scheme and geometry showed an increase of 73.2%. SF-F2 columns showed an increase of 102% in maximum load, while the increase was 51.4% for SA-F2 columns. The same considerations can be made for the case of internal confinement with FRP bars. The case of confinement with both internal FRP bars and external FRP wraps evidenced higher efficiency for hollow-core columns. The increase in terms of ultimate strain was higher for hollow-core columns, in which the presence of a deformable core produced a different behavior with respect to monolithic columns.

The different curvature radius played a significant role on the whole mechanical behavior, in fact SF specimens, having a curvature radius of 20 mm at the corners showed a strength increment of 73.2% with respect to control specimens, while SF specimens with a curvature radius of 10 mm were subjected to premature failure, showing an increment of “only” 49.2%. Higher amount of FRP wraps in SF specimens produced higher confinement efficiency, this was evident for full-core columns, but it resulted in some cases negligible for hollow-core specimens. This is referred to the capacity and deformation. In Table 2 the results of the comparison between experimental values and theoretical results found by using CNR guidelines are shown.

Table 2. Comparison between experimental data and CNR design equations

Specimen	Peak Load (kN)	Computed Peak Load (kN)	
		Theoretical ( $\gamma_{Rd}=1,00$ ; $\eta_s=1,00$ ; $\gamma_r=1,25$ )	considering the model safety factor ( $\gamma_{Rd}=1,10$ ; $\eta_s=1,00$ ; $\gamma_r=1,25$ )
SF-F1-R1	645,85	641,14	582,85
SF1-R2	750,00	685,95	623,59
SF-F2	866,60	938,80	853,45
SF-B1	435,30	464,55	422,32
SF-B2	698,13	529,03	480,94
SF-B1-F1	782,35	823,13	748,30
SF-B2-F1	813,35	891,09	810,08
LF1-R1	1228,00	1078,52	980,47

#### 4 CONCLUSIONS

A research study on the behavior of FRP-confined masonry was presented. Two types of masonry were investigated, the first made with clay bricks, the second made with limestone blocks. Two construction schemes were considered: full-core columns and hollow-core columns, this type reproduces the patterns often found in historical buildings. External and internal FRP confinement were tested, separately and combined. The presence of internal bars used as internal confinement system is recommended in addition to external FRP layers if ductility constitutes a main issue, since in columns strengthened only with bars the ultimate load was increased but brittle behavior of unconfined masonry remained. Columns with hollow core also showed a significant increase of mechanical properties when confinement was applied, especially in the cases of GFRP external sheets combined with internal bars. A comparison between experimental results and equations proposed in CNR DT-200 guidelines was conducted. The results obtained from this study testify that equations reported in the Italian document CNR DT200-2004 can be considered reliable in describing the behavior of FRP-confined masonry for the tested columns. The results of numerical simulations showed that the use of a safety coefficient model should be prescribed as done in the present form of the guidelines. New information and recommendations are easily drawn from the presented research work, which can be used by researchers and practitioners involved in strengthening process of masonry columns.

#### 5 ACKNOWLEDGEMENT

This investigation was supported by the DPC-ReLUIS 2005-2008 project in the research line n.8 “Innovative Materials for Vulnerability mitigation in Existing Structures.

#### 6 REFERENCES

- Aiello M.A, Micelli F, Valente L. (2007), “Structural upgrading of masonry columns by using composite reinforcements”, ASCE J. Compos. for Construction, 11 (6), pp.650-658
- CNR – Italian National Research Council, (2004). Technical Document 200/2004, “Istruzioni per la Progettazione, l’Esecuzione ed il Controllo di Interventi di Consolidamento Statico mediante l’utilizzo di Compositi Fibrorinforzati” - July , 131 pp.
- Kog Y.C., Ong, K.C.G., Yu C.H., and Sreekanth P.V. (2001), “Reinforced Concrete Jacketing for Masonry Columns with Axial Loads”, ACI Materials Journal; 98(2), pp.105-115.
- Krevaikas T.D. and Triantafillou (2006), “Masonry Confinement with Fiber-Reinforced Polymers” ASCE J. Compos. for Constr. 9(2) 2006, pp.128-135.
- Micelli F., De Lorenzis L., La Tegola A. (2003), “Confinement of masonry columns with FRP bars”, Proceedings of CCC2003, Cosenza - September 16-19, pp. 373-378.